

**50:1 RATIO, OUTPUT - 80 CU. IN./MIN.**  
**MIN. AIR PRESSURE - 30 PSI**  
**MAX. AIR PRESSURE - 150 PSI**  
**MAX. OUTPUT PRESSURE - 7500 PSI**

**OWNERS MANUAL**

IT IS THE RESPONSIBILITY OF THE OWNER AND/OR OPERATOR TO PROPERLY USE AND MAINTAIN THIS EQUIPMENT. CAREFULLY READ AND UNDERSTAND THE INSTRUCTIONS AND WARNINGS IN THIS MANUAL BEFORE OPERATING THIS EQUIPMENT.

If the operator is not fluent in English, the instructions and warnings shall be read and discussed in the operator's native language, making sure the operator comprehends the contents.

This equipment complies with OSHA Standards where applicable.

 **WARNING**

DO NOT exceed the stated maximum working pressure of the pump or of the lowest rated component in your system.

DO NOT alter or modify any part of this equipment.

DO NOT operate this equipment with combustible gas.

DO NOT attempt to repair or disassemble the equipment while the system is pressurized.

**TIGHTEN** all fluid connections securely before using this equipment.

**ALWAYS** read and follow the fluid manufacturer's recommendations regarding fluid compatibility, and the use of protective clothing and equipment.

**CHECK** all equipment regularly and repair or replace worn or damaged parts immediately.

**IMPORTANT:** Failure to heed these warnings including misuse, overpressurizing, modifying parts, using incompatible chemicals and fluids, or using worn or damaged parts, may result in equipment damage and/or serious personal injury, fire, explosion, or property damage.

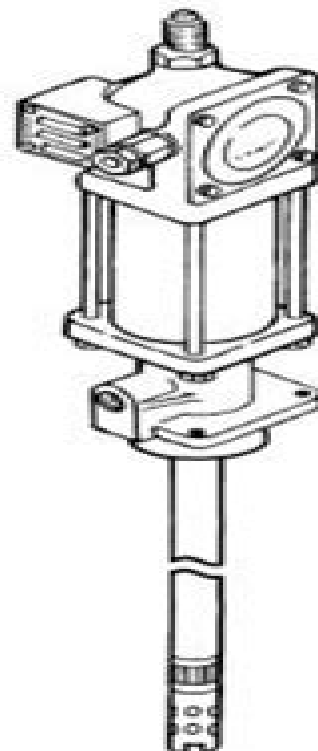

<b>CONTENTS</b>	<b>PAGE</b>
Safety Instructions .....	2
Inspection Instructions .....	2
Damaged Pumps .....	2
Installation .....	2
Operation .....	3
Maintenance .....	3
General Dimensions .....	3
Disassembly Procedure .....	4
Parts Breakdown .....	4-5
Service Parts .....	7
Troubleshooting Chart .....	7
Accessories .....	7
Warranty .....	8

This manual contains **IMPORTANT WARNINGS** and **INSTRUCTIONS** READ AND RETAIN FOR REFERENCE

# **Air Operated Chassis Pump Series F Lincoln Owners Manual**

**H Kauffman**



Air Operated Chassis Pump Series F Lincoln Owners Manual
1952 Lincoln Chassis Repair and Adjustment Manual Ford Motor Company. Lincoln-Mercury Division,1952
Repair Manual Ford Motor Company. Service Department,1947
1952 Lincoln Chassis Shop Manual Ford Motor Company,2020-05-10 This 1952 Lincoln Chassis Shop Manual is a high quality licensed PRINT reproduction of the service manual authored by Ford Motor Company and published by Detroit Iron This OEM factory manual is 8 5 x 11 inches paperback bound shrink wrapped and contains 256 pages of comprehensive mechanical instructions with detailed diagrams photos and specifications for the mechanical components of your vehicle such as the engine transmission suspension brakes fuel exhaust steering electrical and drive line Service repair manuals were originally written by the automotive manufacturer to be used by their dealership mechanics The following 1952 Lincoln models are covered Capri Cosmopolitan This factory written Detroit Iron shop manual is perfect for the restorer or anyone working on one of these vehicles
<b>Lincoln Air-conditioning Manual</b> Ford Motor Company. Lincoln-Mercury Division. Service Department,1954
<b>2018 Lincoln Continental Owner Manual Compatible with OEM Owners Manual, Factory Glovebox Book</b> Helming,2018-06-03
<b>2019 Lincoln Continental Owner Manual Compatible with OEM Owners Manual, Factory Glovebox Book</b> Helming,2019-07-12
<b>Air Pump</b> Douglas J. Reinemann,Michael B. Timmons,1986
2017 Lincoln Continental Owner Manual Compatible with OEM Owners Manual, Factory Glovebox Book Helming,2017-01-03
Owner Manual Compatible with 2020 Lincoln MKC - OEM Owners Manual, Factory Glovebox Book. Helming,2020-01-05
<b>Fleet Owner</b> ,1989
Lincoln Continental Maintenance Manual for 1961 ,1961
1954 Lincoln and Mercury Body-chassis Repair and Adjustment Manual Ford Motor Company. Lincoln-Mercury Division,1953
Chilton's Auto Repair Manual 1982 Alan F. Turner,1981
<b>Lincoln Continental</b> Ford Motor Company,1961
The Naval Aviation Maintenance Program (NAMP).: Maintenance data systems United States. Office of the Chief of Naval Operations,1990
Cars & Parts ,2001
<b>Monthly Catalogue, United States Public Documents</b> ,1990-11
Popular Mechanics ,1955-07 Popular Mechanics inspires instructs and influences readers to help them master the modern world Whether it s practical DIY home improvement tips gadgets and digital technology information on the newest cars or the latest breakthroughs in science PM is the ultimate guide to our high tech lifestyle
Domestic Engineering and the Journal of Mechanical Contracting ,1920

**Bibliography of Scientific and Industrial Reports ,1946**

## **Air Operated Chassis Pump Series F Lincoln Owners Manual** Book Review: Unveiling the Power of Words

In a global driven by information and connectivity, the power of words has be much more evident than ever. They have the ability to inspire, provoke, and ignite change. Such could be the essence of the book **Air Operated Chassis Pump Series F Lincoln Owners Manual**, a literary masterpiece that delves deep into the significance of words and their affect our lives. Compiled by a renowned author, this captivating work takes readers on a transformative journey, unraveling the secrets and potential behind every word. In this review, we shall explore the book is key themes, examine its writing style, and analyze its overall effect on readers.

### **Table of Contents Air Operated Chassis Pump Series F Lincoln Owners Manual**

1. Understanding the eBook Air Operated Chassis Pump Series F Lincoln Owners Manual
  - The Rise of Digital Reading Air Operated Chassis Pump Series F Lincoln Owners Manual
  - Advantages of eBooks Over Traditional Books
2. Identifying Air Operated Chassis Pump Series F Lincoln Owners Manual
  - Exploring Different Genres
  - Considering Fiction vs. Non-Fiction
  - Determining Your Reading Goals
3. Choosing the Right eBook Platform
  - Popular eBook Platforms
  - Features to Look for in an Air Operated Chassis Pump Series F Lincoln Owners Manual
  - User-Friendly Interface
4. Exploring eBook Recommendations from Air Operated Chassis Pump Series F Lincoln Owners Manual
  - Personalized Recommendations
  - Air Operated Chassis Pump Series F Lincoln Owners Manual User Reviews and Ratings
  - Air Operated Chassis Pump Series F Lincoln Owners Manual and Bestseller Lists
5. Accessing Air Operated Chassis Pump Series F Lincoln Owners Manual Free and Paid eBooks
  - Air Operated Chassis Pump Series F Lincoln Owners Manual Public Domain eBooks
  - Air Operated Chassis Pump Series F Lincoln Owners Manual eBook Subscription Services
  - Air Operated Chassis Pump Series F Lincoln Owners Manual Budget-Friendly Options

6. Navigating Air Operated Chassis Pump Series F Lincoln Owners Manual eBook Formats
  - ePub, PDF, MOBI, and More
  - Air Operated Chassis Pump Series F Lincoln Owners Manual Compatibility with Devices
  - Air Operated Chassis Pump Series F Lincoln Owners Manual Enhanced eBook Features
7. Enhancing Your Reading Experience
  - Adjustable Fonts and Text Sizes of Air Operated Chassis Pump Series F Lincoln Owners Manual
  - Highlighting and Note-Taking Air Operated Chassis Pump Series F Lincoln Owners Manual
  - Interactive Elements Air Operated Chassis Pump Series F Lincoln Owners Manual
8. Staying Engaged with Air Operated Chassis Pump Series F Lincoln Owners Manual
  - Joining Online Reading Communities
  - Participating in Virtual Book Clubs
  - Following Authors and Publishers Air Operated Chassis Pump Series F Lincoln Owners Manual
9. Balancing eBooks and Physical Books Air Operated Chassis Pump Series F Lincoln Owners Manual
  - Benefits of a Digital Library
  - Creating a Diverse Reading Collection Air Operated Chassis Pump Series F Lincoln Owners Manual
10. Overcoming Reading Challenges
  - Dealing with Digital Eye Strain
  - Minimizing Distractions
  - Managing Screen Time
11. Cultivating a Reading Routine Air Operated Chassis Pump Series F Lincoln Owners Manual
  - Setting Reading Goals Air Operated Chassis Pump Series F Lincoln Owners Manual
  - Carving Out Dedicated Reading Time
12. Sourcing Reliable Information of Air Operated Chassis Pump Series F Lincoln Owners Manual
  - Fact-Checking eBook Content of Air Operated Chassis Pump Series F Lincoln Owners Manual
  - Distinguishing Credible Sources
13. Promoting Lifelong Learning
  - Utilizing eBooks for Skill Development
  - Exploring Educational eBooks
14. Embracing eBook Trends
  - Integration of Multimedia Elements

- Interactive and Gamified eBooks

### **Air Operated Chassis Pump Series F Lincoln Owners Manual Introduction**

In today's digital age, the availability of Air Operated Chassis Pump Series F Lincoln Owners Manual books and manuals for download has revolutionized the way we access information. Gone are the days of physically flipping through pages and carrying heavy textbooks or manuals. With just a few clicks, we can now access a wealth of knowledge from the comfort of our own homes or on the go. This article will explore the advantages of Air Operated Chassis Pump Series F Lincoln Owners Manual books and manuals for download, along with some popular platforms that offer these resources. One of the significant advantages of Air Operated Chassis Pump Series F Lincoln Owners Manual books and manuals for download is the cost-saving aspect. Traditional books and manuals can be costly, especially if you need to purchase several of them for educational or professional purposes. By accessing Air Operated Chassis Pump Series F Lincoln Owners Manual versions, you eliminate the need to spend money on physical copies. This not only saves you money but also reduces the environmental impact associated with book production and transportation. Furthermore, Air Operated Chassis Pump Series F Lincoln Owners Manual books and manuals for download are incredibly convenient. With just a computer or smartphone and an internet connection, you can access a vast library of resources on any subject imaginable. Whether you're a student looking for textbooks, a professional seeking industry-specific manuals, or someone interested in self-improvement, these digital resources provide an efficient and accessible means of acquiring knowledge. Moreover, PDF books and manuals offer a range of benefits compared to other digital formats. PDF files are designed to retain their formatting regardless of the device used to open them. This ensures that the content appears exactly as intended by the author, with no loss of formatting or missing graphics. Additionally, PDF files can be easily annotated, bookmarked, and searched for specific terms, making them highly practical for studying or referencing. When it comes to accessing Air Operated Chassis Pump Series F Lincoln Owners Manual books and manuals, several platforms offer an extensive collection of resources. One such platform is Project Gutenberg, a nonprofit organization that provides over 60,000 free eBooks. These books are primarily in the public domain, meaning they can be freely distributed and downloaded. Project Gutenberg offers a wide range of classic literature, making it an excellent resource for literature enthusiasts. Another popular platform for Air Operated Chassis Pump Series F Lincoln Owners Manual books and manuals is Open Library. Open Library is an initiative of the Internet Archive, a non-profit organization dedicated to digitizing cultural artifacts and making them accessible to the public. Open Library hosts millions of books, including both public domain works and contemporary titles. It also allows users to borrow digital copies of certain books for a limited period, similar to a library lending system. Additionally, many universities and educational institutions have their own digital libraries that provide free access to PDF books and manuals. These libraries often offer academic

texts, research papers, and technical manuals, making them invaluable resources for students and researchers. Some notable examples include MIT OpenCourseWare, which offers free access to course materials from the Massachusetts Institute of Technology, and the Digital Public Library of America, which provides a vast collection of digitized books and historical documents. In conclusion, Air Operated Chassis Pump Series F Lincoln Owners Manual books and manuals for download have transformed the way we access information. They provide a cost-effective and convenient means of acquiring knowledge, offering the ability to access a vast library of resources at our fingertips. With platforms like Project Gutenberg, Open Library, and various digital libraries offered by educational institutions, we have access to an ever-expanding collection of books and manuals. Whether for educational, professional, or personal purposes, these digital resources serve as valuable tools for continuous learning and self-improvement. So why not take advantage of the vast world of Air Operated Chassis Pump Series F Lincoln Owners Manual books and manuals for download and embark on your journey of knowledge?

### **FAQs About Air Operated Chassis Pump Series F Lincoln Owners Manual Books**

How do I know which eBook platform is the best for me? Finding the best eBook platform depends on your reading preferences and device compatibility. Research different platforms, read user reviews, and explore their features before making a choice. Are free eBooks of good quality? Yes, many reputable platforms offer high-quality free eBooks, including classics and public domain works. However, make sure to verify the source to ensure the eBook credibility. Can I read eBooks without an eReader? Absolutely! Most eBook platforms offer webbased readers or mobile apps that allow you to read eBooks on your computer, tablet, or smartphone. How do I avoid digital eye strain while reading eBooks? To prevent digital eye strain, take regular breaks, adjust the font size and background color, and ensure proper lighting while reading eBooks. What the advantage of interactive eBooks? Interactive eBooks incorporate multimedia elements, quizzes, and activities, enhancing the reader engagement and providing a more immersive learning experience. Air Operated Chassis Pump Series F Lincoln Owners Manual is one of the best book in our library for free trial. We provide copy of Air Operated Chassis Pump Series F Lincoln Owners Manual in digital format, so the resources that you find are reliable. There are also many Ebooks of related with Air Operated Chassis Pump Series F Lincoln Owners Manual. Where to download Air Operated Chassis Pump Series F Lincoln Owners Manual online for free? Are you looking for Air Operated Chassis Pump Series F Lincoln Owners Manual PDF? This is definitely going to save you time and cash in something you should think about. If you trying to find then search around for online. Without a doubt there are numerous these available and many of them have the freedom. However without doubt you receive whatever you purchase. An alternate way to get ideas is always to check another Air Operated Chassis Pump Series F Lincoln Owners Manual. This method for see exactly what may be included and adopt these ideas to



your book. This site will almost certainly help you save time and effort, money and stress. If you are looking for free books then you really should consider finding to assist you try this. Several of Air Operated Chassis Pump Series F Lincoln Owners Manual are for sale to free while some are payable. If you arent sure if the books you would like to download works with for usage along with your computer, it is possible to download free trials. The free guides make it easy for someone to free access online library for download books to your device. You can get free download on free trial for lots of books categories. Our library is the biggest of these that have literally hundreds of thousands of different products categories represented. You will also see that there are specific sites catered to different product types or categories, brands or niches related with Air Operated Chassis Pump Series F Lincoln Owners Manual. So depending on what exactly you are searching, you will be able to choose e books to suit your own need. Need to access completely for Campbell Biology Seventh Edition book? Access Ebook without any digging. And by having access to our ebook online or by storing it on your computer, you have convenient answers with Air Operated Chassis Pump Series F Lincoln Owners Manual To get started finding Air Operated Chassis Pump Series F Lincoln Owners Manual, you are right to find our website which has a comprehensive collection of books online. Our library is the biggest of these that have literally hundreds of thousands of different products represented. You will also see that there are specific sites catered to different categories or niches related with Air Operated Chassis Pump Series F Lincoln Owners Manual So depending on what exactly you are searching, you will be able to choose ebook to suit your own need. Thank you for reading Air Operated Chassis Pump Series F Lincoln Owners Manual. Maybe you have knowledge that, people have search numerous times for their favorite readings like this Air Operated Chassis Pump Series F Lincoln Owners Manual, but end up in harmful downloads. Rather than reading a good book with a cup of coffee in the afternoon, instead they juggled with some harmful bugs inside their laptop. Air Operated Chassis Pump Series F Lincoln Owners Manual is available in our book collection an online access to it is set as public so you can download it instantly. Our digital library spans in multiple locations, allowing you to get the most less latency time to download any of our books like this one. Merely said, Air Operated Chassis Pump Series F Lincoln Owners Manual is universally compatible with any devices to read.

### **Find Air Operated Chassis Pump Series F Lincoln Owners Manual :**

**yoga philosophy of patanjali containing his yoga**

[1999 nissan maxima repair manual](#)

[hospitality marketing management 5th edition](#)

**replacing oil cooler lines chevy blazer**

[chemistry 1032 broward college final exam](#)

[logic design interview questions](#)

[pci erectors manual standards](#)

[the cellar 1 natasha preston](#)

[the great turkey race](#)

[chemistry zumdahl 9th edition ap multiple choice answers](#)

**benson microbiology lab manual answers**

~~[optimal control theory applications to management science \(international series in management science/operations resear\)](#)~~

**nilsson riedel electric circuits 8th edition solution manual**

[lesson 2 activity 13 microeconomics answers](#)

[radio shack electronics learning lab manual](#)

### **Air Operated Chassis Pump Series F Lincoln Owners Manual :**

[ask a librarian old exam papers university of south africa](#) - Aug 14 2023

web aug 7 2023 the short answer is no the library does not keep old examination papers however previous examination papers usually for the preceding year are made

[unisa past exam papers with answers edt101g bespoke cityam](#) - Mar 29 2022

web may 27 2023 unisa past exam papers with answers edt101g unisa past exam 5 unisa exam tips that will help you pass student news unisa past papers online

[unisa past exam questions paper free previous](#) - May 11 2023

web unisa exam past questions download free previous exam questions papers and answers here you will download freeunisa previous exam questions unisa past

**unisa past exam papers with answers edt101g zuzutop com** - Jan 07 2023

web of our books as soon as this one merely said the unisa past exam papers with answers edt101g is universally compatible as soon as any devices to read asem jan

[unisa past exam papers with answers edt101g pdf](#) - Mar 09 2023

web unisa past exam papers with answers edt101g the enigmatic realm of unisa past exam papers with answers edt101g unleashing the language is inner magic in a

**university of south africa unisa past exam papers pdf** - Apr 10 2023

web jan 20 2022 download unisa exams past papers pdf download note study each question in the past paper carefully because most of the exam questions that will be

**unisa past exam papers with answers edt101g** - Jul 01 2022

web download free unisa past exam papers with answers edt101g conference of the southern african computer lecturers association on ict education sacla 2016 held

**unisa past exam papers with answers edt101g pdf uniport edu** - Dec 06 2022

web mar 31 2023 unisa past exam papers with answers edt101g 1 9 downloaded from uniport edu ng on march 31 2023 by guest unisa past exam papers with answers

*university of south africa unisa exam past questions papers* - Jul 13 2023

web jun 17 2022 university of south africa unisa past exam papers pdf download how to get the most recent and free unisa examination past questions papers and

**get the free unisa past exam papers download pdf form pdffiller** - Sep 03 2022

web 01 students who want to practice and improve their understanding of the course material 02 those who wish to familiarize themselves with the format and style of the exams 03

how to get unisa past question papers demzyportal - Oct 04 2022

web the unisa student portal is where you can find the unisa past exam papers below is the step by step guide visit the unisa student learning portal myunisa click on the login

**unisa past exam papers with answers edt101g** - Dec 26 2021

web april 8th 2018 browse and read unisa past exam papers with answers edt101g unisa past exam papers with answers edt101g new updated the unisa past exam

**unisa past exam papers with answers edt101g darelova** - May 31 2022

web may 22 2023 month browse and read unisa past exam papers with answers edt101g unisa past exam papers with answers edt101g new updated the unisa

*unisa past exam papers with answers edt101g copy uniport edu* - Oct 24 2021

web start getting this info acquire the unisa past exam papers with answers edt101g connect that we provide here and check out the link you could buy guide unisa past exam

*unisa past exam papers with answers edt101g 2022* - Nov 05 2022

web 4 unisa past exam papers with answers edt101g 2021 07 22 icel 2018 13th international conference on e learning siber ink this book is essential for academics

*unisa past exam papers pdf download infopportunity* - Nov 24 2021

web the university of south africa unisa exams committee has made available the past papers for previous exams conducted by the institution kindly follow the below lead to

**previous exam papers and solutions university of** - Aug 02 2022

web good morning kindly assist me with the age1501 examination questions and memorandum for may june 2017 2018 papers please send on my email

unisa past papers and notes my courses - Jun 12 2023

web jul 12 2020 check out unisa previous question papers and memorandum unisa past papers and notes previous examination papers usually for the preceding year are

unisa past exam papers with answers edt101g pdf pdf 2023 - Jan 27 2022

web unisa past exam papers with answers edt101g pdf pdf upload caliva p ferguson 1 1 downloaded from vla ramtech uri edu on august 14 2023 by caliva p ferguson unisa

**unisa past exam papers with answers edt101g secure4 khronos** - Feb 25 2022

web answers edt101g what you analogous to download access the unisa past exam papers with answers edt101g join that we have the funds for here and check out the link book

**unisa past exam papers with answers edt101g pdf pdf** - Sep 22 2021

web unisa past exam papers with answers edt101g pdf upload dona b williamson 1 22 downloaded from voto uncal edu br on august 17 2023 by dona b williamson unisa

*unisa past exam papers with answers edt101g 2022* - Apr 29 2022

web unisa past exam papers with answers edt101g is nearby in our digital library an online right of entry to it is set as public correspondingly you can download it instantly our

previous question papers and memorandums - Feb 08 2023

web can someone please help me with previous question papers as well as memorandums and send them to 61458252 mylife unisa ac za abt1517 abt1518 abt1519 abt1520

*alfred s beginning drumset method learn how to play drumset* - Aug 02 2022

web product details description this book and dvd kit provides a practical approach to playing the drumset students start their first lesson by actually playing a beat the book and

*alfred s beginning drumset method drumset book alfred music* - Jan 07 2023

web alfred s beginning drumset method book and dvd descriptionthis book and dvd kit provides a practical approach to playing the drumset students start their first lesson by

**alfred s beginning drumset method** - Feb 25 2022

web alfred s beginning drumset method book dvd dave black sandy feldstein on amazon com au free shipping on eligible orders alfred s beginning drumset

**alfred s beginners drumset method amazon com au** - Jul 01 2022

web alfred s beginning drumset method drumset book online video audio 21 99 view alfred s beginning drumset method drum dvd 19 95 view alfred s beginning

**alfred s beginning drumset method book dvd paperback** - Oct 24 2021

alfred s beginning drumset method drumset cd alfred - Mar 09 2023

web details reviews q a tech specs related posts this book and dvd kit provides a practical approach to playing the drumset

**alfred s drumset method book 2** - May 31 2022

web alfred s beginning drumset method 23 99 brand new 30 day return policy alfred s beginning drumset method by dave black and sandy feldstein 00 23201 19 99

*alfred s beginning drumset method drum dvd alfred* - Aug 14 2023

web this dvd provides a practical approach to playing the drumset students start their first lesson by actually playing a beat the disc is divided into two sections rock and jazz

**beginning drumset method alfred s drumset method** - Apr 29 2022

web this book and dvd kit provides a practical approach to playing the drumset students start their first lesson by actually playing a beat the book and disc are divided into two

alfred beginning drumset method reverb - Nov 24 2021

*alfred s beginning drumset method book and dvd* - Dec 06 2022

web drumset beginner composed by dave black and sandy feldstein artist personality method instruction percussion drum set method or collection alfred s drumset

**alfred s beginning drumset method alfred music** - Jul 13 2023

web description this book video and audio kit provides a practical approach to playing the drumset students start their first lesson by actually playing a beat the book and video

**alfred s beginners drumset method amazon com** - Nov 05 2022

web may 3 2005 alfred s beginning drumset method learn how to play drumset with this innovative method alfred s drumset method kindle edition by black dave

**alfred alfred s beginning drumset method book dvd sleeve** - Dec 26 2021

*alfred s beginning drumset method book dvd* - Jun 12 2023

web jan 1 2005 alfred s beginning drumset method book dvd paperback dvd january 1 2005 by dave black author sandy

feldstein author 4 6 4 6 out of 5 stars

[alfred s beginning drumset method reverb](#) - Sep 03 2022

web drumset book cd alfred s drumset method book 2 is a continuation of alfred s beginning drumset method the rock and jazz vocabularies previously learned in book

**alfred alfreds beginning drum set method with online** - May 11 2023

web essential dvd collection a step by step instructional dvd designed to guide and motivate beginning drummers based out of minneapolis we tour the country looking

*alfred s beginning drumset method reverb* - Jan 27 2022

**alfred s beginning drumset method alfred music** - Mar 29 2022

web alfred s beginning drumset method by dave black and sandy feldstein 00 23201

**alfred s beginning drumset method instructional dvd reverb** - Apr 10 2023

web alfred s beginning drumset method drumset book online video audio 21 99 view alfred s beginning drumset method drumset book 9 99 view alfred s beginning

**alfred s drum method** - Oct 04 2022

web alfred s beginners drumset method dave black sandy feldstein on amazon com au free shipping on eligible orders alfred s beginners drumset method

*alfred alfred s beginning drumset method book dvd sleeve* - Feb 08 2023

web by dave black and sandy feldstein drumset book this innovative method is a practical approach to playing the drumset students start their first lesson by actually playing a

**classifying wastes answer key uniport edu ng** - Aug 27 2022

web oct 20 2023 classifying wastes answer key 1 1 downloaded from uniport edu ng on october 20 2023 by guest classifying wastes answer key eventually you will no

**classifying wastes answer key portal nivbook co il** - Sep 08 2023

web classifying wastes answer key 1 classifying wastes answer key safe management of wastes from health care activities fundamentals of environmental chemistry third

[classifying wastes answer key analytics test makestories io](#) - Jun 24 2022

web classifying wastes answer key when somebody should go to the ebook stores search opening by shop shelf by shelf it is in point of fact problematic this is why we provide

**balancing classifying reactions unit lab examples of** - Nov 29 2022

web description this pdf document includes the student sheet and teacher resources answer key for a balancing classifying reactions unit lab named examples of chemical

*classifying wastes answer key store spiralny com* - Nov 17 2021

web 2 classifying wastes answer key 2022 12 19 experiments the book offers prudent practices designed to promote safety and it includes practical information on assessing

**250 top mcqs on classification lists of wastes and answers** - Aug 07 2023

web basic hazardous waste management questions and answers on classification lists of wastes 1 how many lists are observed according to cfr a 1 b 2 c 3 d 4

**classifying wastes answer key pdf pdf** - Dec 31 2022

web introduction classifying wastes answer key pdf pdf emergency response guidebook u s department of transportation 2013 06 03 does the identification

classifying wastes printable 6th 10th grade teachervision - Oct 09 2023

web exclusive pbl projects for busy teachers ready to print easy to implement students classify common examples of solid wastes and identify disposal methods assesses

learning task 1 classify the given wastes into its proper brainly - Feb 18 2022

web learning task 1 classify the given wastes into its proper type write your answers inside the garbage bin do this task on your answer sheet styrofoam banana peelings used

*classifying wastes answer key cyberlab sutd edu sg* - Oct 29 2022

web classifying wastes answer key the management of world wastes nov 01 2022 activities and answer key to create a well rounded lesson plan key waste jan 03

ebook classifying wastes answer key - Jun 05 2023

web classifying wastes answer key waste the global view waste management success stories gr 5 8 feb 19 2022 final quiz answer key and color mini posters all of our

**periodic table nomenclature lab classifying elements lab** - May 24 2022

web this extensive bundle could be used as a complete periodic table nomenclature unit within a high school chemistry course the bundle includes three powerpoint

*hazardous waste management questions and answers* - Mar 22 2022

web this set of basic hazardous waste management questions and answers focuses on classification lists of wastes 1 how many lists are observed according to cfr a

**classifying wastes answer key api4 nocvedcu cz** - Mar 02 2023

web 4 classifying wastes answer key 2022 12 23 prudent practices in the laboratory national academies press solid waste management affects every person in the world

**balancing classifying reactions unit lab forming** - Oct 17 2021

web description this pdf document includes the student sheet and teacher resources answer key for a balancing classifying reactions unit lab named forming precipitates

classifying wastes answer key mucho goldenpalace - Dec 19 2021

web 2 classifying wastes answer key 2021 12 04 chapters 4 and 5 introduce the guiding regulatory principles for developing local or national approaches to tackling health care

**classifying wastes answer key graph safhousetech com** - Apr 03 2023

web classifying wastes answer key 3 3 improvements improvements to this version include foundational content about processes what they are and how they vary a description

**classifying wastes answer key uniport edu ng** - Sep 27 2022

web jul 5 2023 classifying wastes answer key 1 1 downloaded from uniport edu ng on july 5 2023 by guest classifying wastes answer key when people should go to the book

classifying wastes answer key app acumed net - Jan 20 2022

web classifying wastes answer key threatened planet evs 9 food preservation in developing countries challenges and solutions safe management of wastes from

classifying wastes answer key discover designlights org - Feb 01 2023

web 2 classifying wastes answer key 2023 10 17 classifying wastes answer key omb no edited by madeline rhys safe management of wastes from health care activities

world amr awareness week 2023 unep - Apr 22 2022

web 2 days ago when 18 24 november 2023 where worldwide antimicrobial resistance amr occurs when bacteria viruses fungi and parasites no longer respond to

**classifying wastes answer key uniport edu ng** - Jul 26 2022

web oct 11 2023 classifying wastes answer key 2 12 downloaded from uniport edu ng on october 11 2023 by guest using the most economical methods available the major

*solved which type of waste is classified as hazardous* - May 04 2023

web recyclable waste food waste garden waste paper waste textile waste etc hazardous waste hazardous waste is waste that has substantial or potential threats to public

**classifying wastes answer key** - Jul 06 2023



web classifying wastes answer key this is likewise one of the factors by obtaining the soft documents of this classifying wastes answer key by online you might not require